

Complete stainless steel Permanent Magnet servomotors

ABI b.v., located in Haarlem, Holland, has been developing and manufacturing electric motors and gear motors since 1955. Responding to market needs, ABI has developed a completely stainless steel aseptic electric motor, specially designed for markets dealing with high standards in hygiene and cleaning. This range is further expanded and a full stainless steel servomotor series has recently been added to the program. The range is characterized by high levels of quality and reliability. Years of experience, market feedback and optimization of the design ensure that our motors live up to your expectations, even in the toughest of environments.

IP69k / PW12

The motors are manufactured out of AISI 316L, DIN 1.4404. The protection class is IP69k; which means that the motors are pressure washer proof according to DIN-40050. The maximum water pressure is 100bar, with a maximum temperature of 80°C. This assures effortless high pressure cleaning. Stainless steel motors often fail because of moisture (condensation) which builds up in the motor over time. This is caused by a combination of temperature changes, wash downs at different temperatures and a high humidity environment. Specially designed seals and pressure proof chambers in the ABI motors prevent this moisture build-up.

Fields of application for these motors are environments which have to conform to the HACCP regulations as well as situations with special requirements regarding hygiene and cleaning or extremely humid environments. For example: food and dairy production, meat and poultry processing and the pharmaceutical industry.

Minimal TCO and machine downtime

By choosing an ABI stainless steel servo motor, you contribute to a lower energy consumption, and the motor can offer you a considerable reduction in costs over time.

In the long run 'Total Cost of Ownership' is more important than the initial purchase price of a machine. In tough conditions, where corrosion or wear by moisture occurs, it has been proven that an IP69k motor (our ABI quality) has a much longer life span than a lower quality motor. Next to the cost reductions by greatly reducing machine downtime, this also cuts down on replacement costs of the motors themselves.

Because of high efficiency and a longer life span, the ABI stainless steel motors add to a much lower TCO.



Product range

ABI supplies the following product range

Stainless steel motors, 0.18-4kW, in 2, 4, 6 and 8 pole versions. Available in B14, B5 and B3 mounting positions, both in non-ventilated (TENV) and water cooled (TELC) designs

Stainless steel worm gear motors in 2 sizes, up to a maximum torque of appr. 80Nm, in the most common ratios (from 3.6:1 to 75:1)

Stainless steel planetary gearboxes with IEC mounting position. Type PRS80 (up to 130Nm) and type PRS120 (up to 260Nm). These completely sealed (IP69k) stainless steel planetary gearboxes can be attached to IEC motors

Stainless steel helical bevel gearboxes. The KRSH4 is a 3 stage gearbox available in ratios from 6,62:1 – 319:55:1. The maximum torque is 310 Nm

Stainless steel brush / brushless DC motors in 2 and 4 pole version, with powers up to 200W, in both 24 and 48Vdc

Stainless PM servo motors in 4 sizes with torque to 17Nm and speeds up to 3000rpm

Stainless PM servo motors

The ABI stainless steel PM servomotors are high quality products.

Suitable for the most extreme conditions in, for example, the food processing industry. The motors are characterized by a very smooth appearance, which leaves no areas where germs or dirt can collect. The RVS316L (1.4404) permanent magnet SMRS series fully comply with the extremely strict EHEDG standardization.

A specially designed seal system around the stainless steel output shaft provides an IP69K enclosure, ensuring a long life. Only FDA approved materials and lubricants are used.



- 4 sizes 70, 85, 100 and 140
- Torque up to 17Nm
- Peak torque up to 111Nm
- speed 3000 rpm
- Laser coded type shield
- RVS316L (1.4404) housing
- Temperature sensor KTY84-130
- Mounting B5
- Conform EHEDG
- cUL-Listed



SMRS070 Specifications

Parameter	Symbol	Unit	SMRS070A	SMRS070B	SMRS070C
Stall torque	M_o	Nm	0,85	1,4	1,85
Rated torque	M_N	Nm	0,7	1,0	1,35
Rated speed	n_N	min^{-1}	3000	3000	3000
Rated power	P_N	kW	0,22	0,31	0,42
Peak torque	M_{max}	Nm	6,1	11,66	17,19
Stall current	I_o	A_{rms}	0,65	1,0	1,25
Rated current	I_N	A_{rms}	0,6	0,8	1,15
Peak current	I_{max}	A_{rms}	5,5	9,6	12,9
Torque constant	k_t	Nm/A_{rms}	1,3	1,4	1,48
Voltage constant <small>phase-phase 20°C</small>	k_e	$\text{mV}_{\text{rms}}/\text{min}^{-1}$	98	100	98
Resistance <small>phase-phase 20°C</small>	R	Ω	51,0	21,0	13,2
Inductance <small>phase-phase</small>	L	mH	185,0	101,0	60,6
Pole pairs	P	-	4	4	4
Inertia	J	kgcm^2	0,47	0,85	1,23
Weight	m	kg	3,0	3,7	4,4

Specifications based on 3 x 400Vac

Optional holding brake

			SMRS070A	SMRS070B	SMRS070C
Holding torque <small>at 120°C</small>	M_{br}	Nm		2,0	
Power at 24Vdc	P_{br}	W		11	
Motor inertia with brake	J	kgcm^2	0,55	0,93	1,31
Weight motor and brake	m	kg	3,6	4,3	5,0



Dimensions

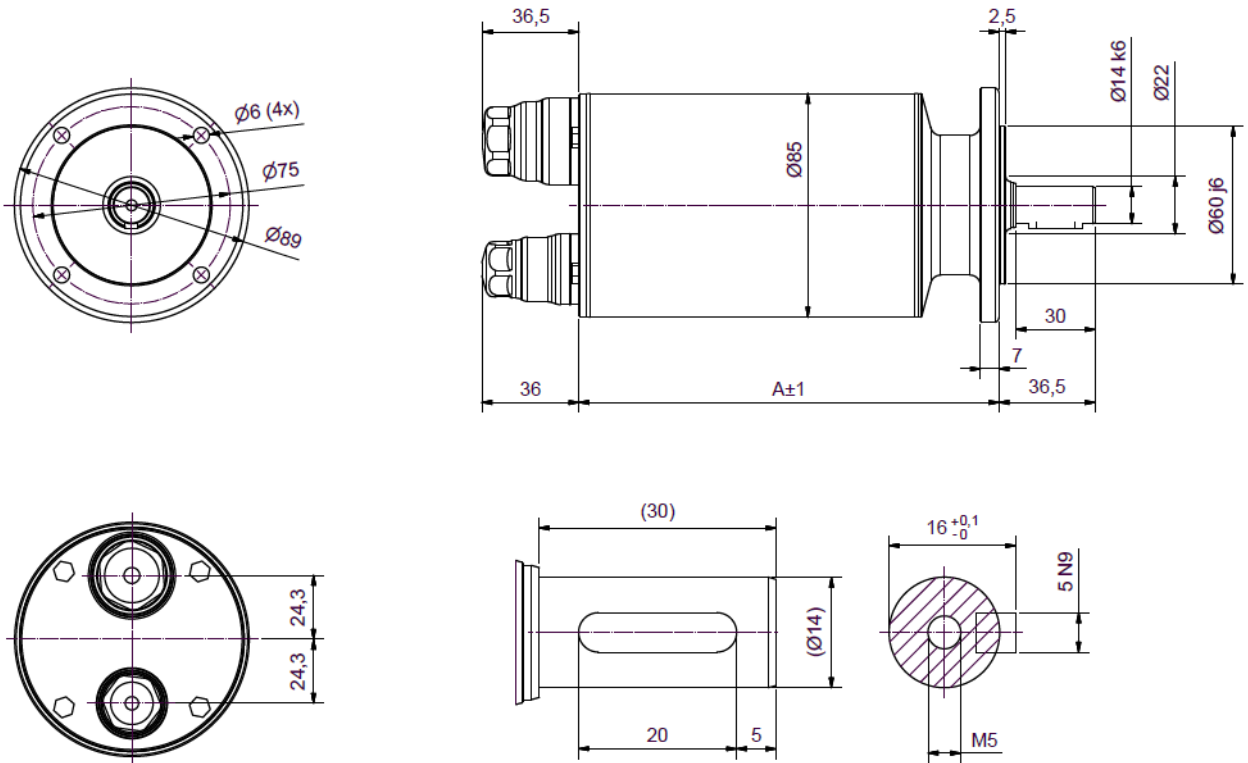

			SMRS070A	SMRS070B	SMRS070C
Length without brake	A	mm	134,0	159,5	185,0
Length with brake	A	mm	172,0	197,5	223,0
Center bore			DIN 332-D M5		
Keyway			DIN 6885-A(S) 5 x 5 x 20		
Connection			Cable gland connection		
Recommended mounting bolts on delivery incl. Sealing according to ISO 4017-M5 x 13					



SMRS085 Specifications

Parameter	Symbol	Unit	SMRS085A	SMRS085B	SMRS085C
Stall torque	M_o	Nm	1,6	2,6	3,45
Rated torque	M_N	Nm	1,3	1,9	2,75
Rated speed	n_N	min^{-1}	3000	2500	2500
Rated power	P_N	kW	0,41	0,5	0,72
Peak torque	M_{\max}	Nm	9,17	18,94	29,33
Stall current	I_o	A_{rms}	1,1	1,6	1,9
Rated current	I_N	A_{rms}	0,95	1,1	1,4
Peak current	I_{\max}	A_{rms}	7,5	11,8	16,6
Torque constant	k_t	Nm/A_{rms}	1,45	1,62	1,81
Voltage constant <small>phase-phase 20°C</small>	k_e	$\text{mV}_{\text{rms}}/\text{min}^{-1}$	101	128	131
Resistance <small>phase-phase 20°C</small>	R	Ω	22,5	14,2	8,9
Inductance <small>phase-phase</small>	L	mH	98,2	81,0	59,1
Pole pairs	P	-	4	4	4
Inertia	J	kgcm^2	1,12	2,01	2,90
Weight	m	kg	4,8	5,9	7,1

Specifications based on 3 x 400Vac

Optional holding brake

			SMRS085A	SMRS085B	SMRS085C
Holding torque <small>at 120°C</small>	M_{br}	Nm		9,0	
Power at 24Vdc	P_{br}	W		18	
Motor inertia with brake	J	kgcm^2	1,77	2,66	3,55
Weight motor and brake	m	kg	5,9	7,0	8,2



Dimensions

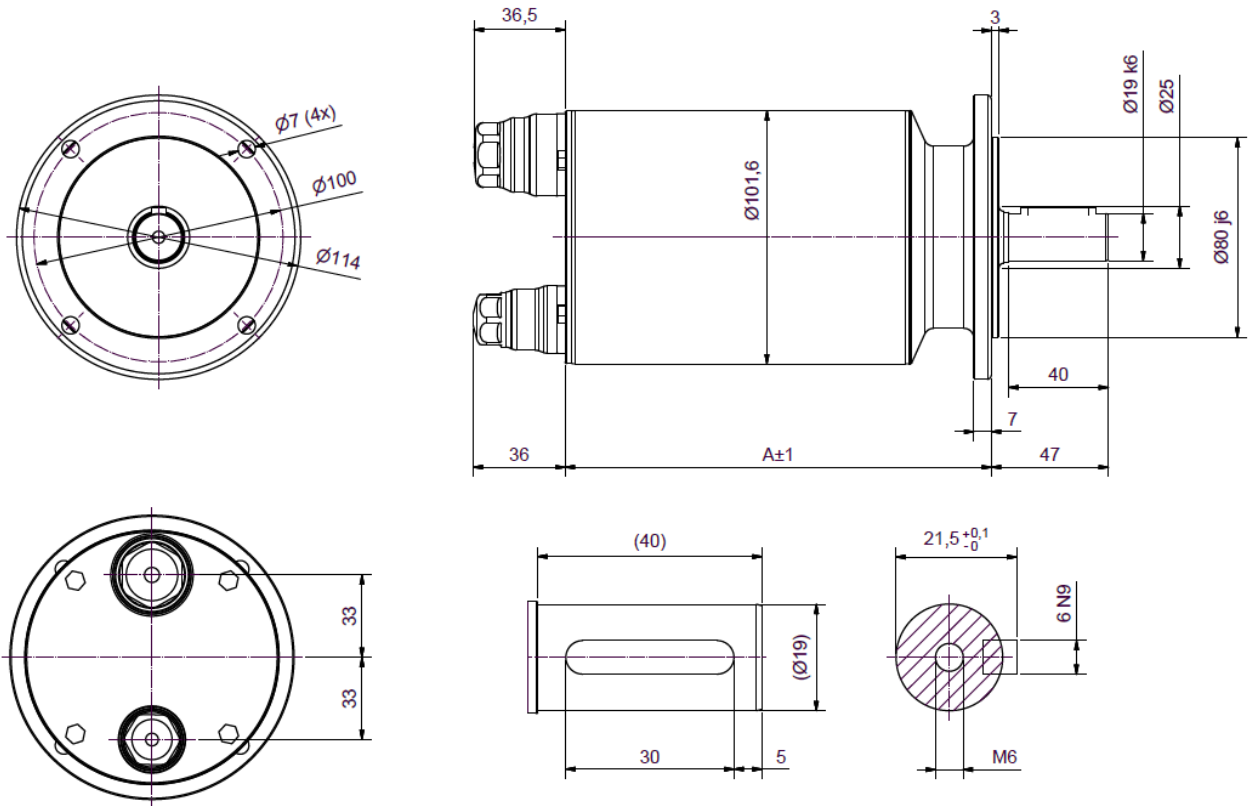

			SMRS085A	SMRS085B	SMRS085C
Length without brake	A	mm	141,0	171,0	201,0
Length with brake	A	mm	188,0	218,0	248,0
Center bore			DIN 332-D M6		
Keyway			DIN 6885-A(S) 6 x 6 x 30		
Connection			Cable gland connection		
Recommended mounting bolts on delivery incl. Sealing according to ISO 4017-M6 x 15					



SMRS100 Specifications

Parameter	Symbol	Unit	SMRS100A	SMRS100B	SMRS100C
Stall torque	M_o	Nm	3,1	4,8	6,4
Rated torque	M_N	Nm	2,7	3,7	4,3
Rated speed	n_N	min^{-1}	2500	2000	2000
Rated power	P_N	kW	0,71	0,78	0,9
Peak torque	M_{\max}	Nm	17,74	35,32	53,13
Stall current	I_o	A_{rms}	1,8	2,1	2,8
Rated current	I_N	A_{rms}	1,7	1,7	1,95
Peak current	I_{\max}	A_{rms}	12,1	17,9	36,9
Torque constant	k_t	Nm/A_{rms}	1,72	2,28	2,28
Voltage constant <small>phase-phase 20°C</small>	k_e	$\text{mV}_{\text{rms}}/\text{min}^{-1}$	125	167	168
Resistance <small>phase-phase 20°C</small>	R	Ω	11,4	8,5	5,1
Inductance <small>phase-phase</small>	L	mH	53,7	48,6	33,2
Pole pairs	P	-	4	4	4
Inertia	J	kgcm^2	2,32	4,15	5,98
Weight	m	kg	6,5	8,3	10,1

Specifications based on 3 x 400Vac

Optional holding brake

			SMRS100A	SMRS100B	SMRS100C
Holding torque <small>at 120°C</small>	M_{br}	Nm		9,0	
Power at 24Vdc	P_{br}	W		18	
Motor inertia with brake	J	kgcm^2	2,98	2,98	2,98
Weight motor and brake	m	kg	7,7	7,7	7,7



Dimensions

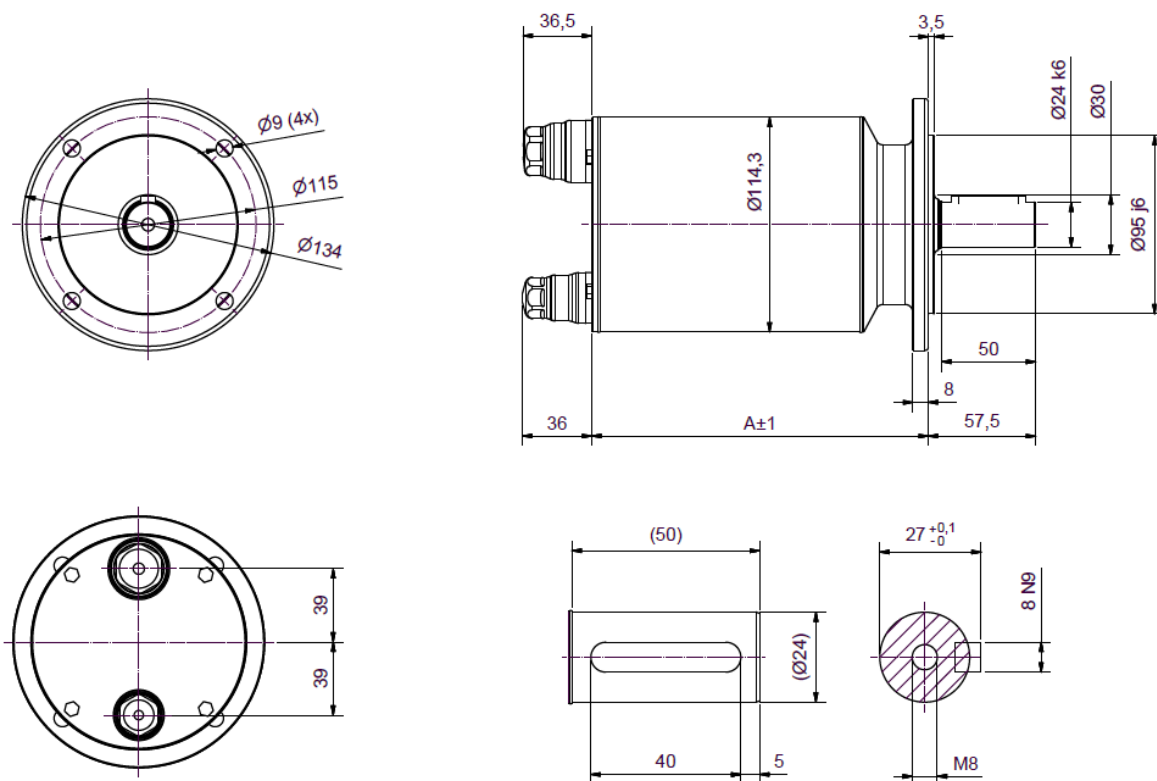

			SMRS100A	SMRS100B	SMRS100C
Length without brake	A	mm	146,0	179,0	212,0
Length with brake	A	mm	192,0	225,0	258,0
Center bore			DIN 332-D M8		
Keyway			DIN 6885-A(S) 8 x 7 x 40		
Connection			Cable gland connection		
Recommended mounting bolts on delivery incl. Sealing according to ISO 4017-M8 x 18					



SMRS140 Specifications

Parameter	Symbol	Unit	SMRS140A	SMRS140B	SMRS140C
Stall torque	M_o	Nm	7,75	13,1	16,7
Rated torque	M_N	Nm	6,2	8,9	8,0
Rated speed	n_N	min^{-1}	1500	1500	1500
Rated power	P_N	kW	0,97	1,4	1,26
Peak torque	M_{max}	Nm	37,1	74,16	110,95
Stall current	I_o	A_{rms}	2,53	4,1	4,9
Rated current	I_N	A_{rms}	2,15	3,1	2,6
Peak current	I_{max}	A_{rms}	13,9	27,0	38,9
Torque constant	k_t	Nm/A_{rms}	3,06	3,19	3,4
Voltage constant <small>phase-phase 20°C</small>	k_e	$\text{mV}_{\text{rms}}/\text{min}^{-1}$	223	234	240
Resistance <small>phase-phase 20°C</small>	R	Ω	7,0	2,95	1,95
Inductance <small>phase-phase</small>	L	mH	65,9	35,4	25,2
Pole pairs	P	-	5	5	5
Inertia	J	kgcm^2	11,4	20,4	29,3
Weight	m	kg	14,8	18,9	23,2

Specifications based on 3 x 400Vac

Optional holding brake

			SMRS140A	SMRS140B	SMRS140C
Holding torque <small>at 120°C</small>	M_{br}	Nm		20,0	
Power at 24Vdc	P_{br}	W		24	
Motor inertia with brake	J	kgcm^2	13,7	22,6	31,5
Weight motor and brake	m	kg	17,3	21,4	25,7



Dimensions

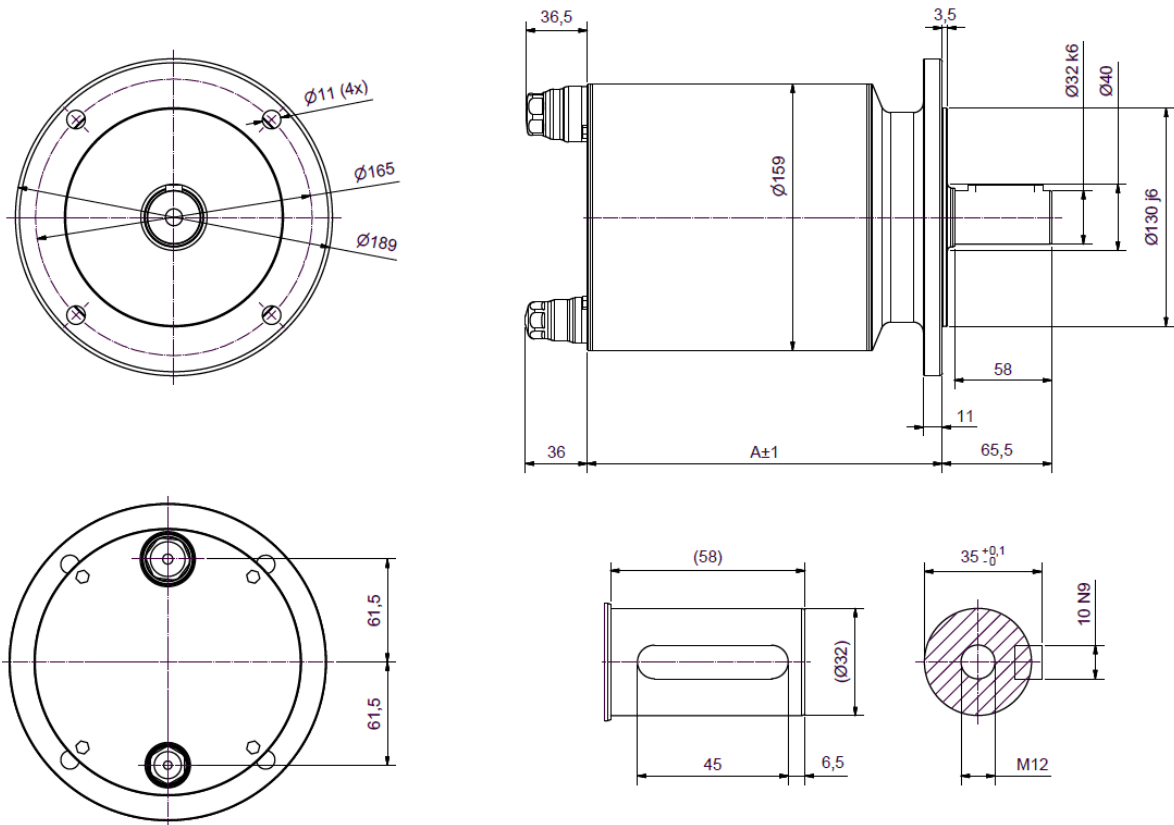

			SMRS140A	SMRS140B	SMRS140C
Length without brake	A	mm	171,5	221,5	251,5
Length with brake	A	mm	221,5	261,5	301,5
Center bore			DIN 332-D M12		
Keyway			DIN 6885-A(S) 10 x 8 x 45		
Connection			Cable gland connection		
Recommended mounting bolts on delivery incl. Sealing according to ISO 4017-M10 x 25					



Type key

Type parameter	Description	Code	Explanation
SMRS070A-5-25-xx			
SMRS070A-5-25-xx	Flange size		
		070	Ø70 mm
		085	Ø85 mm
		100	Ø100 mm
		140	Ø140 mm
SMRS070A-5-25-xx	Motor length		
		A	Small
		B	Medium
		C	Large
SMRS070A-5-25-xx	DC link voltage		
		3	325Vdc (230Vac)
		5	565Vdc (400Vac)
SMRS070A-5-25-xx	Motor speed		
		15	1500rpm
		20	2000rpm
		25	2500rpm
		30	3000rpm
SMRS070A-5-25-xx	Options		
		00	No additional options

ABI b.v.

A.Hofmanweg 60
2031BL Haarlem
The Netherlands

Phone: +31(0)23 5319292
Fax: +31(0)23 5326599
info@abi.nl

All data is considered preliminary and subject to change without prior notice
2019-V2

